

Bike Accident Detection System

A. Arun¹, Ms. E. Durga Nandini², Ms. Sarika jain³, Dr. S. Geetha⁴

¹M.Sc – CFIS, Department of Computer Science and Engineering, Dr. M.G.R Educational and Research Institute, Chennai 600 095, Tamilnadu, India

^{2,3}Center of Excellence in Digital Forensics, Chennai 600 089, Tamilnadu, India

⁴Head of the Department, Department of Computer Science and Engineering, Dr. M.G.R Educational and Research Institute, Chennai 600 095, Tamilnadu, India

Abstract

Road accidents are one of the major causes of fatalities. The time between the occurrence of the accident and the emergency medical facility provided at the accident location is an important factor in the survival rates after the accident. By reducing the time between the accident and the medical facility provided to the scene decreases mortality rates so that more lives can be saved. Using Accident Detection Using Arduino, which issues a warning if an accident happened and quickly tells the emergency personnel, is one way to end that wait. According to the description of the system, its primary use is to identify accidents using vibration sensors and send an alert signal to the appropriate locations. Alert messages include the location of the accident and alcohol. In this approach, the latitude and longitude values are originally collected via GPS from the satellite. To track a vehicle, we need to send a message to the GSM device to activate it. It also gets activated by detecting the accident on the vibration sensor connected to the Arduino controller. Once the GSM is activated, it receives the last latitude and longitude position value and sends a message to the emergency number which is predefined in the program.

Keywords: Bike accident detection, GPS, GSM, Arduino.

1. Introduction

The high demand for vehicles has also increased the traffic problems and the road accidents. Due to driver's carelessness there occur to demand chief road accidents with the cities, but also outside the city, accidents mostly occur due to drunken driving. Not only drunken driving, but also driving rudely without wearing seat belts causes a loss of lives. Due to this the life of public is at high risk. The reason behind this is the lack of the best emergency facilities available in our country. An automatic alert system with maximum information of the accident is introduced in this paper. The proposed system, which can detect accidents in significantly less time and sends the information to the emergency centre within a few seconds which covers the exact location where the accident has occurred and also the information such as the speed, alcohol percentage, has put the seat belt or not, number of members in the vehicle. This alert message has been sent to the emergency server which will inform ambulances and police stations near that location and also to the insurance office, which will help to save valuable lives. A switch is also provided near the driver seat in order to terminate the sending of message in rare cases where there are no casualties, this can save the precious time of ambulance, police. When an accident occurs the alert message is sent automatically to the emergency server. This

message was sent through the GSM module and a location is being detected with the help of the GPS module. The accident can be detected precisely using a vibration sensor. This application provides an excellent solution to the poor emergency facilities which are provided to the road accidents in most possible ways.

2. Objectives and Scope

The main objective of this project is to prevent casualties which happen due to lack of medical assistance in time. Certainly, if the accident happens due to other cases, the using embedded devices will be able to provide the spontaneous message and exact location to hospital in order to recover victims. Avoiding casualties caused by road accidents is the main goal of this paper, with the help of Accelerometer and GPS present in the mobile phones. Based on the data collected from these sensors, which are present in most mobile phones, the location of the accident is sent at the same time of the accident to the friends and relatives which the user allowed and stored, and also to the rescue and emergency services.

3. Existing System

This idea proposal has been introduced at the start of the modern age of mobile phones. With the introduction of GPS sensors in the mobile, security applications based on GPS were proposed. Then they proposed special hardware devices which can be linked with mobile phones. Though, it had the disadvantage of actually buying extra hardware with more money. With the massive development of mobile phones in the last decade and new sensors added with the development, the extra hardware can be avoided. The present application of this paper is present in a very few countries and providing the information with the relatives and friends with the emergency services the efficiency of the application can be increased massively.

4. Proposed Method

The main idea of this paper is to build an embedded device that makes use of the sensors which are used in microcontroller GPS and Accelerometer and detect any collision if there is a sudden external disturbance in the speed with the help of the Sensor Based Algorithm. With the help of the data obtained from the Accelerometer sensor, when there is a sudden disturbance to the mobile phone, the user is notified with an alert message before sending the request help signal. If no emergency is required, the gsm sends the alert message in 30 seconds, message will be sent to the emergency services as well as the family members, the users provided phone number.

5. Architecture Diagram



Fig 1: Architecture Diagram

- Import the necessary libraries (e.g., Software Serial, Adafruit Sensor, Adafruit_ADXL345_U.)
- Initialize the accelerometer sensor by setting its pin as input and enabling the internal pull-up resistor.
- Create a call back function that will be called whenever the accelerometer sensor changes its state.
- Connect the call back function to the sensor using the `add_event_detect` method
- Initialize the GPS module and retrieve the current location data.
- Use location data for find the latitude and longitude,
- Store the phone numbers of the closest person number in a list.
- Initialize the GSM module and set it up for text messaging.
- Iterate over the list of phone numbers and make calls to each number
- Save the text messages of vehicle number sent
- It will choose the Random contact number like sos.
- Clean up GPIO and other resources when the program terminates.

6. Modules and Project Description

Arduino: The Arduino UNO is a widely used open-source microcontroller board based on the ATmega328P microcontroller and developed by Arduino.cc. The Arduino is the major control unit to detect or alert when an accident occurs. It collects the data from vibration sensors, GPRS and GSM modules and reflects the output through a message. Here the accelerometer sensor plays a major role. This accelerometer sensor will receive the motion of the bike which is fell in same axis for 30 sec the vehicle which in turn acts as an accident detection module. Arduino gathers the information from all other modules and sends the message to the receiver through the GSM module.

GSM Module: For providing communication between the GPS, GSM and the allocated mobile number GSM SIM900 module is preferred. The name SIM900 says that it is a tri-band work ranging a frequency of 900MHz to 1900 MHz such as EGSM900 MHz, PCS 1900 MHz and DSC 100 MHz Receiving pin of the GSM module and the transmitting pin of the GPS module are used for communication between the modules and the mobile phone.

GPS Module: To find the location on the earth the whole is divided into some coordinates where the location can be easily captured by a module called GPS module. Here the GPS used is SIM800L. This GPS module will find the location of the vehicle and the information fetched by the GPS receiver is received through the coordinates the received data is first sent to Arduino and the information is transmitted to the saved contact through the GSM module. The frequency is operated in the range of 1575.42 MHz and the output of the GPS module is in NMEA format which includes data like location in real-time.

7. Circuit Diagram

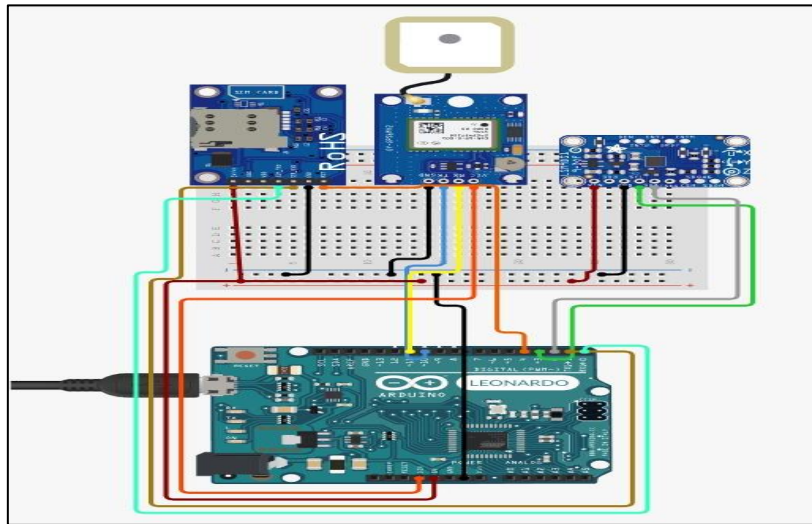

Fig 2: Circuit Diagram

8. Screenshots

```
377 Serial.print("https://maps.google.com / maps ? f = q&q = ")
378 NodeSerial.print(lat);
379 NodeSerial.print(",");

Output Serial Monitor x

Message (Enter to send message to 'Arduino Uno' on 'COM4')

02:26:58.605 -> X: 0 Y: 8 Z: 5 A: 5 accident: 14 bcc: 14 Wcc:
02:27:00.093 -> X: 0 Y: 8 Z: 5 A: 5 accident: 15 bcc: 15 Wcc:
02:27:00.129 -> AT
02:27:01.079 -> AT+CMGF=1
02:27:02.092 -> AT+CMGS="+919092700000,"
02:27:03.089 -> ht0.0000,0.0000
02:27:04.073 -> □
02:27:11.698 -> X: 0 Y: 0 Z: 9 A: 0 accident: 1 bcc: 0 Wcc:
02:27:13.193 -> X: 0 Y: 0 Z: 9 A: 0 accident: 2 bcc: 0 Wcc:
02:27:14.701 -> X: 0 Y: 0 Z: 9 A: 0 accident: 3 bcc: 0 Wcc:
02:27:16.210 -> X: 0 Y: 0 Z: 9 A: 0 accident: 4 bcc: 0 Wcc:
02:27:17.695 -> X: 0 Y: 0 Z: 9 A: 0 accident: 5 bcc: 0 Wcc:
```

Fig 3: Output on Arduino Serial Monitor

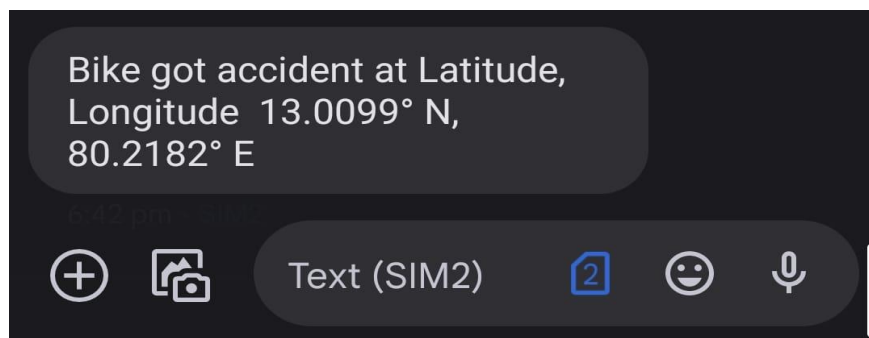

Fig 4: Notification Message

9. Conclusion

The proposed system provides emergency medical service as soon as possible and avoids mortality. This is to provide the details of the accident that occurred and the area of the accident with other information. It helps to easily provide facility and help to the victims of the accident. GSM is used to provide information regarding the accident and a GPS module is used to trace the location of the vehicle. The proposed programmed accident detection system can be a rescuer of life for the people who met with accidents. The proposed system is exceptionally easy to understand and even a non-specialized Person can use it without any problem. The system consists of equipment and programming segments. accident detection sensors that are constrained by an Arduino board and are fitted in the vehicle. In general, the benefits of this system are low cost, secure and simple to use. The system introduced in this work reduces the casualties due to accidents.

References

- [1] DR.C.K.Gomathy, V.Geetha, S.Madhumitha, S.Sangeetha, R.Vishnupriya Article: A Secure With Efficient Data Transaction In Cloud Service, Published by International Journal of Advanced Research in Computer Engineering & Technology (IJARCET) Volume 5 Issue 4, March 2016, ISSN: 2278 – 1323.
- [2] Dr C.K.Gomathy, C K Hemalatha, Article: A Study On Employee Safety And Health Management International Research Journal Of Engineering And Technology (Irjet)- Volume: 08 Issue: 04 | Apr 2021\
- [3] Dr C K Gomathy, Article: A Study on the Effect of Digital Literacy and Information Management, IAETSD Journal for Advanced Research in Applied Sciences, Volume 7 Issue 3, P. No-51-57, ISSN NO: 2279-543X, Mar/2018
- [4] Dr C K Gomathy, Article: An Effective Innovation Technology in Enhancing Teaching and Learning of Knowledge Using Ict Methods, International Journal of Contemporary Research in Computer Science and Technology (Ijrcrst) E-Issn: 2395-5325 Volume3, Issue 4, P. No-10-13, April '2017
- [5] Dr C K Gomathy, Article: Supply Chain-Impact of Importance and Technology in Software Release Management, International Journal of Scientific Research in Computer Science Engineering and Information Technology (IJSRCSEIT) Volume 3 | Issue 6 | ISSN: 2456-3307, P. No:1-4, July-2018.

- [6] C K Gomathy and V Geetha. Article: A Real-Time Analysis of Service based using Mobile Phone Controlled Vehicle using DTMF for Accident Prevention. International Journal of Computer Applications 138(2):11-13, March 2016. Published by Foundation of Computer Science (FCS), NY, USA, ISSN No: 0975-8887
- [7] C K Gomathy and V Geetha. Article: Evaluation of Ethernet-based Passive Optical Network Service Enhancement through Splitting of Architecture. International Journal of Computer Applications 138(2):14-17, March 2016. Published by Foundation of Computer Science (FCS), NY, USA, ISSN No: 0975-8887
- [8] C.K.Gomathy and Dr.S.Rajalakshmi.(2014), "A Software Design Pattern for Bank Service Oriented Architecture", International Journal of Advanced Research in Computer Engineering and Technology (IJARCET), Volume 3, Issue IV, April 2014, P. No:1302-1306, ISSN:2278-1323.
- [9] C. K. Gomathy and S. Rajalakshmi, "A software quality metric performance of professional management in service-oriented architecture," Second International Conference on Current Trends in Engineering and Technology - ICCTET 2014, 2014, pp. 41-47, doi: 10.1109/ICCTET.2014.6966260.
- [10] Xie, D.; Xu, Y.; Wang, R. Obstacle detection and tracking method for autonomous vehicle based on three-dimensional LiDAR. Int. J. Adv. Robot. Syst. 2019, 16. [Google Scholar] [CrossRef] [Green Version]
- [11] Malinverno, M.; Mangues-Bafalluy, J.; Casetti, C.E.; Chiasserini, C.F.; Requena-Esteso, M.; Baranda, J. An Edge-Based Framework for Enhanced Road Safety of Connected Cars. IEEE Access 2020, 8, 58018–58031. [Google Scholar] [CrossRef]
- [12] Patnayak, S.; Swain, A.; Das, M. Advance Anti-collision Device for Vehicles Using GPS and Zigbee. In Innovations in Soft Computing and Information Technology; Springer: Singapore, 2019; pp. 117–123. [Google Scholar] [CrossRef]